



**BERLI**<sup>®</sup>  
MACCHINE AGRICOLE

**ECO *sprint***<sup>®</sup> / **easy**  
**ECO *sprint***<sup>®</sup>  
**ECO *sprint***<sup>®</sup> / **D**  
**ECO *row***  
**ECO *row*** / **D**



**Diserbatrici interfilari**



**Between row grass & weed mowers**



**Mäher zur Spalierpflege**



**Machines à désherber entre rangées**



**Desbrozadoras de interfilas**



L'esperienza di 60 anni nel settore delle macchine agricole permette alla ditta Berti di offrire alla sua vasta clientela una gamma completa di attrezzature tecnologicamente avanzate al servizio di un'agricoltura sempre più esigente e specializzata. La qualità dei prodotti fin dalla materia prima, la volontà di soddisfare sempre e prima di tutto le esigenze della clientela, la robustezza, l'affidabilità, hanno dato vita al largo consenso che queste macchine hanno ricevuto in tutto il mondo.



The experience of 60 years in the manufacturing of farm implements makes it possible for Berti Company to offer a complete range of technologically advanced mulchers and shredders, to serve a more and more demanding and specialized agriculture.

The high quality, the sturdiness and the reliability of the products, the will to satisfy always the customer's requirement are the reasons of the large success enjoyed by these implements worldwide.





Die Firma Berti hat 60 Jahre Erfahrung auf dem Gebiet der Landwirtschaftsmaschinen und ist also imstande, ihren zahlreichen Kunden eine komplette Palette von technologisch fortgeschrittenen Landwirtschaftsausrüstungen zu Verfügung zu stellen.

Die Produktqualität, gekennzeichnet durch die Wahl von Rohstoffen erster Klasse, die Beständigkeit und die Zuverlässigkeit der Maschinen, hat die Firma in die Lage gesetzt, diese in der ganzen Welt einzusetzen.



L'expérience acquise au cours de 60 ans dans le monde de la machine agricole permet à la firme Berti d'offrir à ses nombreux clients une gamme complète d'équipements technologiquement à l'avant-garde au service d'une agriculture exigeante et professionnelle. La qualité des produits à partir de la matière première, la volonté de satisfaire surtout les exigences de la clientèle, la résistance et la fiabilité ont permis à nos machines d'obtenir un accueil très favorable dans le monde entier.



La experiencia de 60 años en el sector de las máquinas agrícolas ha permitido a la empresa Berti ofrecer a sus clientes una gama completa de equipos tecnológicamente avanzados para una agricultura cada vez más especializada. Gracias a la robustez y a la fiabilidad de los productos y a una calidad que se busca incluso en las materias primas empleadas, unido a la voluntad de satisfacer siempre y en primer lugar las exigencias de los clientes, Berti se ha hecho famosa en todo el mundo.

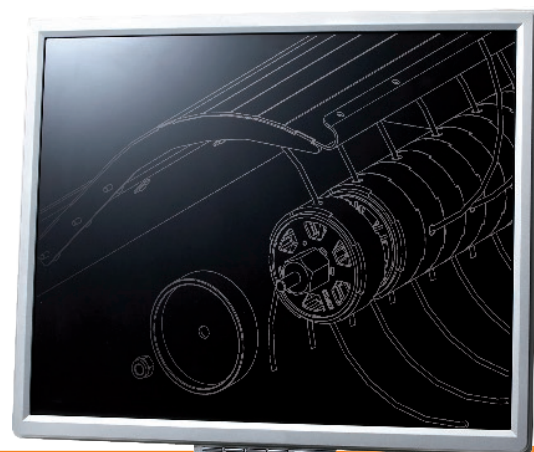

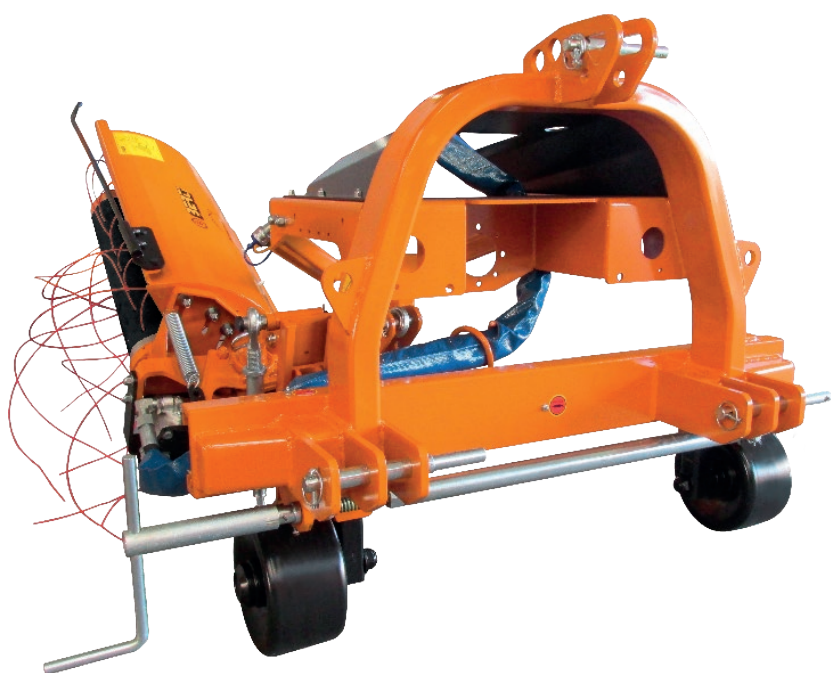

# ECOSprint® / easy





**HARDOX®**  
WEAR PLATE









 Diserbatrice idraulica interfilare singola. Idonea per lo sfalcio delle erbe infestanti sottofila su vigneti e frutteti in generale. Studiata per le piccole e medie imprese. Equipaggiata con telaio indipendente.

 Hydraulic Between-Row Weed-Mower with single head and independent frame, ideal for all ecological and mechanical controls of the weeds in vineyard and orchard. It is driven by the tractor's hydraulics. Equipped with independent frame.

 Hydraulische Maher mit eigenem Rahmen. Zur Spalierpflege im Wein-und Obstbauen. Zur hydraulisch Steuerung des Traktors.

 Machine à désherber hydraulique entre rangées avec tête de broyage et structure indépendant. Conçue pour couper l'herbe sous les arbres dans des vergers et des vignobles. Avec structure indépendante.

 Desbrozadora de interfilas hidráulica con un solo cabezal para la limpieza mecánica entre las líneas de la plantas en viñedos y frutales. Este modelo está provisto de un bastidor independiente.

Mod.	 HP								
	Min	Max	cm	n°	mm	α°	mm	min	max
<b>ECOSPRINT EASY 90-140</b>	30	70	75	16	900 1400	55°	120	225	285
<b>ECOSPRINT EASY 140-240</b>	40	80	75	16	1400 2400	55°	120	255	315

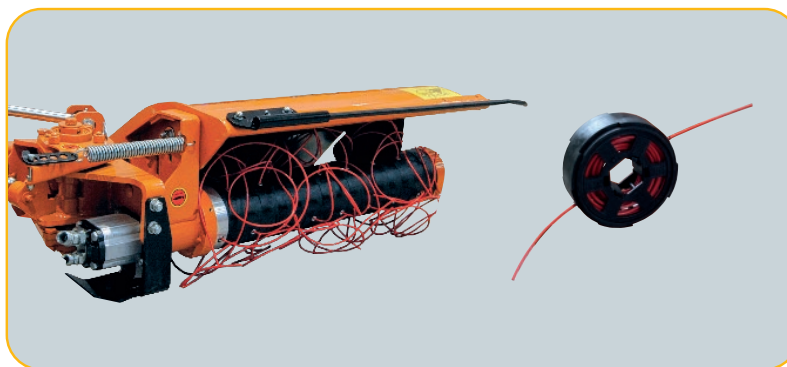

- Telaio con attacco ai tre punti spostabile meccanicamente I-II<sup>A</sup> Cat.
- Independent Frame with displaceable 3-point linkage Cat I-II.(mechanical).
- Eigene Tragrahmen mit Versetzbarem Dreipunkbock Kat. I-II.(mechanischer).
- Structure indépendante avec attelage déportable à 3 points cat. I et II (mécanique).
- Conexión independiente a los 3 puntos desplazable, Cat. I-II (desplazamiento mecánico).

- Testata completa di bobine (brevettato).
- Mower head with for wire-spools (patented).
- Mähkopf mit Drahtspulen (patentiert).
- Tête de broyage avec bobines de fil (brevété).
- Cabezal desbrozador con carretes de filamentos de Nylon (patentado).

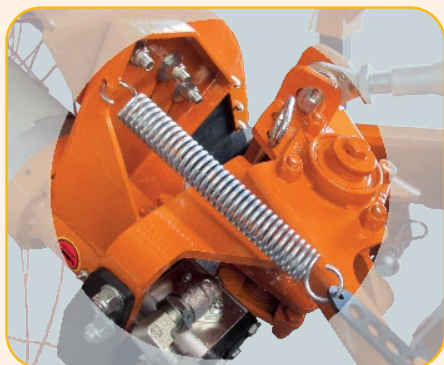

- Tensionamento meccanico della testata.
- Mechanical tensioning of the head.
- Mechanische Spannung des Kopfes.
- Tension mécanique de la tête.
- Tensor mecánico de la cabeza.



- Regolazione meccanica dell'altezza e dell'inclinazione di lavoro.
- Manual height and tilt adjustment.
- Mechanische Höhenverstellung Neigungsverstellung.
- Réglage mécanique de l'hauteur et de l'inclinaison.
- Ajuste mecánico de altura e inclinación.

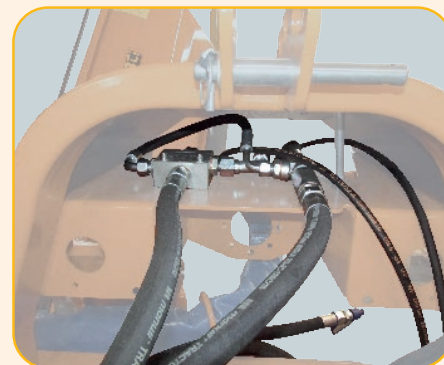

- Regolatore di flusso.
- Flow regulator.
- Mengenregler.
- Régulateur de flux.
- Regulador de flujo.

## OPTIONALS



- Scambiatore di calore.
- Oil Cooler.
- Ölkühler.
- Refroidisseur d'huile.
- Refrigerador de aceite.



- Ruote (n°3) in gomma regolabili in altezza.
- Supporting rubber wheels (n°3), height adjustable.
- Höhenverstellbare Stützräder (N°3) aus Gummi.
- Roues de caoutchouc (n°3), réglables en hauteur.
- Ruedas de goma (n°3) regulables en altura.



- Avvolgifilo meccanico.
- Mechanical winder for wire-spool.
- Wickelapparat für Drahtspule.
- Bobineuse mécanique pour fil.
- Enrollador mecánico de los filamentos.

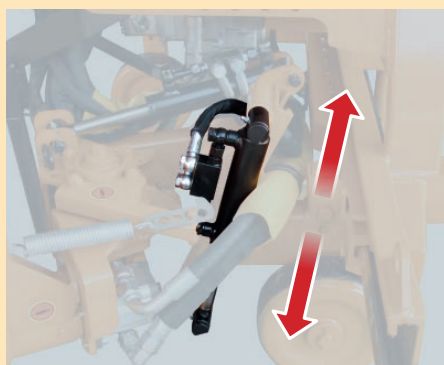

- Martinetto idraulico per la regolazione dell'altezza di lavoro completo di tubi ed innesti rapidi.
- Hydr. cylinder for height of mower head with hydraulic hoses and quick couplers.
- Hydr. Zylinder für Höhenverstellung des Mähkopf mit Schläuchen und Schnellkupplungen.
- Vérin hydraulique pour réglage de l'hauteur de la tête, avec flexibles et prises rapides.
- Cilindro hidráulico para ajuste de altura del cabezal con mangueras hidráulicas y acopladores rápidos.

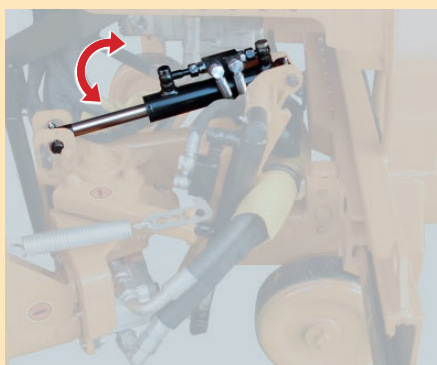

- Martinetto idraulico per la regolazione dell'inclinazione di lavoro completo di tubi ed innesti rapidi.
- Hydr. cylinder for tilt adjustment of mower head with hydraulic hoses and quick couplers.
- Hydr. Zylinder für Neigungsverstellung des Mähkopf mit Schläuchen und Schnellkupplungen.
- Vérin hydraulique pour réglage de l'inclinaison de la tête, avec flexibles et prises rapides.
- Cilindro hidráulico para ajuste de inclinación del cabezal con mangueras hidráulicas y acopladores rápidos.

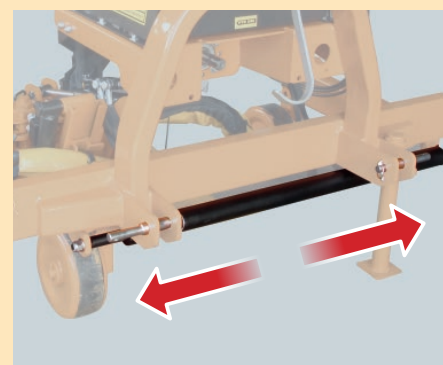

- Martinetto idraulico per lo spostamento laterale completo di tubi ed innesti rapidi.
- Hydr. cylinder for side shift with hydraulic hoses and quick couplers.
- Hydr. Zylinder für Seitenverschiebung mit Schläuchen und Schnellkupplungen.
- Vérin hydraulique pour déport avec flexibles et prises rapides.
- Cilindro hidráulico de desplazamiento lateral con mangueras hidráulicas y acopladores rápidos.

# ECOsprint®





**HARDOX®**  
WEAR PLATE











 Diserbatrice idraulica interfila a singola testata. Idonea per lo sfalcio e diserbo meccanico dell'erba sottofila su vigneti e frutteti in generale. Equipaggiata con telaio e impianto idraulico indipendenti.

 Hydraulic Between-Row Mower with single head, equipped with independent frame and hydraulic system. Ideal for all ecological and mechanical control of the weeds in vineyard and orchard.

 Hydraulische Mahler mit eigenem Rahmen und hydraulischer Anlage. Zur Spalierpflege im Wein- und Obstbau. Geeignet zu alle Typen von Traktoren.

 Machine à désherber hydraulique entre rangées avec simple tête de broyage. Conçue pour couper l'herbe sous les arbres dans des vergers et des vignobles. Disponible système hydraulique autonome et structure indépendante.

 Desbrozadora de interfilas hidráulica con un solo cabezal para la limpieza mecánica entre las líneas de la plantas en viñedos y frutales. Este modelo está provisto de un bastidor portante y de un sistema hidráulico independiente.

Mod.	 HP		 L						
	Min	Max	cm	n°	mm	α°	cm	min	max
<b>ECOSPRINT 90-140</b>	40	100	75	16	900 1400	-5° → +45°	10	470	530
<b>ECOSPRINT 140-240</b>	50	100	75	16	1400 2400	-5° → +65°	15	510	570

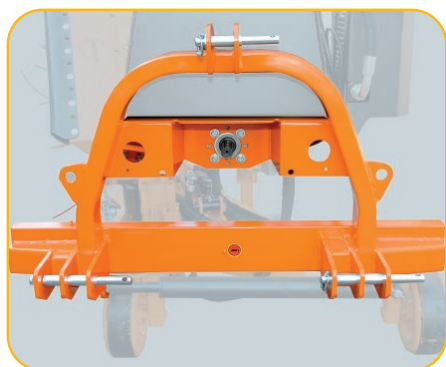

- Telaio con attacco ai tre punti I-II<sup>A</sup> Cat.
- Independent Frame with 3-point linkage Cat I-II.
- Eigene Tragrahmen mit Dreipunkbock Kat. I-II.
- Structure indépendante avec attelage 3 points cat. I et II.
- Conexión independiente al 3º punto del tractor, Cat I y II.

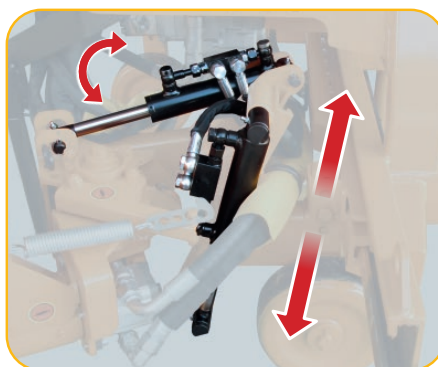

- Martinetti idraulici per la regolazione dell'altezza e dell'inclinazione di lavoro completi di tubi ed innesti rapidi.
- Hydr. cylinders for height and tilt adjustment of mower head with hydraulic hoses and quick couplers.
- Hydr. Zylinder für Höhenverstellung und Neigungsverstellung des Mähkopf mit Schlauchen und Schnellkupplungen.
- Vérins hydrauliques pour réglage de l'hauteur et de l'inclinaison de la tête, avec flexibles et prises rapides.
- Cilindros hidráulicos para ajuste de altura e inclinación del cabezal con mangueras hidráulicas y acopladores rápidos.

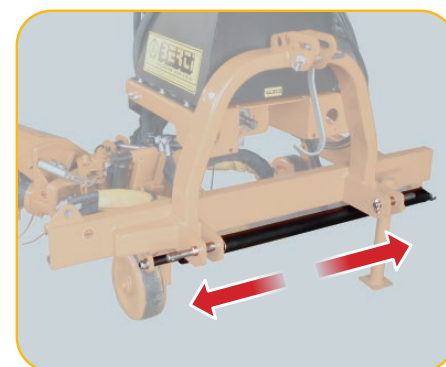

- Martinetto idraulico per lo spostamento laterale completo di tubi ed innesti rapidi.
- Hydr. cylinder for side shift with hydraulic hoses and quick couplers.
- Hydr. Zylinder für Seitenverschiebung mit Schlauchen und Schnellkupplungen.
- Vérin hydraulique pour déport avec flexibles et prises rapides.
- Cilindro hidráulico de desplazamiento lateral con mangueras hidráulicas y acopladores rápidos.



- Tensionamento meccanico della testata.
- Mechanical tensioning of the head.
- Mechanische Spannung des Kopfes.
- Tension mécanique de la tête.
- Tensor mecánico de la cabeza.



- Testata completa di bobine (brevettato).
- Mower head with for wire-spools (patented).
- Mähkopf mit Drahtspulen (patentiert).
- Tête de broyage avec bobines de fil (breveté).
- Cabezal desbrozador con carretes de filamentos de Nylon (patentado).



- Centralina oleodinamica autonoma.
- Independent hydraulic system.
- Hydraulische Selbstversorgungsanlage.
- Centrale hydraulique indépendante.
- Sistema hidráulico independiente.

## OPTIONALS



- Scambiatore di calore.
- Oil Cooler.
- Ölkühler.
- Refroidisseur d'huile.
- Refrigerador de aceite.



- Cavi teleflessibili con leve per comando martinetti.
- Flexible cables with levers for controlling the cylinders.
- Fernbedienung mit Bowdenzüge zur Steuerung der Zylinder.
- Câbles flexibles avec leviers pour contrôler les cylindres.
- Cables flexibles con palancas para controlar los cilindros.



- Ruote (n°3) in gomma regolabili in altezza.
- Supporting rubber wheels (n°3), height adjustable.
- Höhenverstellbare Stützräder (N°3) aus Gummi.
- Roues de caoutchouc (n°3), réglables en hauteur.
- Ruedas de goma (n°3) regulables en altura.

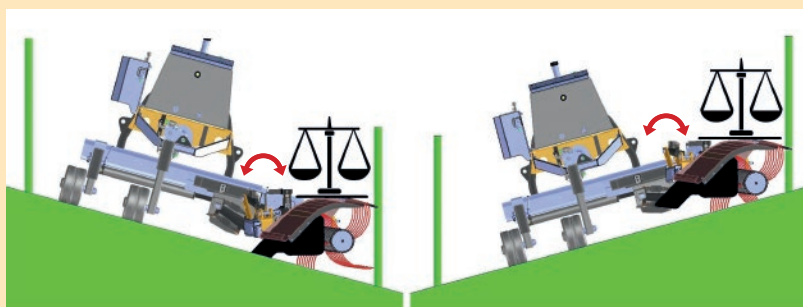

- Kit per contropendenze con tubi e innesti rapidi.
- Kit for counter-slopes with hoses and quick couplings.
- Satz für Gegenhänge.
- Kit pour contrepenches avec tuyaux et prises rapides.
- Kit para adaptarse a la pendiente de trabajo con tubos y acoples rápidos.



- Comando elettrico Joystick con distributore ed elettrovalvole.
- Electric Controls for all functions.
- Elektrische Steuerung mit Joystick Bedienung (alle Funktionen).
- Commande électrique avec joystick pour toutes les fonctions.
- Control electrónico de funciones con Joystick.



- Avvolgifiilo meccanico.
- Mechanical winder for wire-spool.
- Wickelapparat für Drahtspule.
- Bobineuse mécanique pour fil.
- Enrollador mecánico de los filamentos.



- Albero cardanico.
- Pto drive shaft.
- Gelenkwelle.
- Arbre cardan.
- Eje cardan.

# ECOSprint® /D

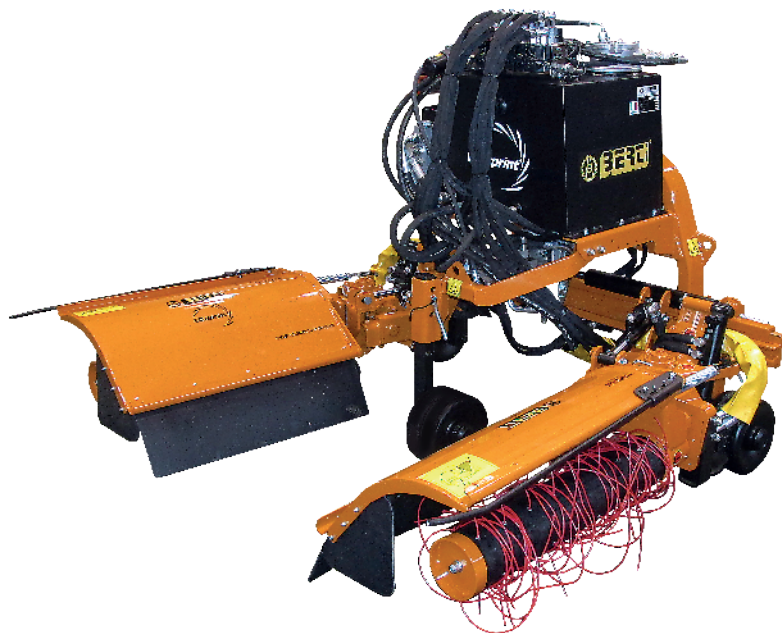



**HARDOX®**  
WEAR PLATE











 Diserbatrice idraulica interfilare a doppia testata. Idonea per lo sfalcio e diserbo meccanico dell'erba sottofila su vigneti e frutteti in generale. Equipaggiata con telaio e impianto idraulico indipendenti.

 Hydraulic Between-Row Mower with twin head, equipped with independent frame and hydraulic system. Ideal for all ecological and mechanical control of the weeds in vineyard and orchard.

 Hydraulische Mahler mit doppeltem Rahmen und hydraulisch Anlage. Zur Spalierpflege im Wein- und Obstbau. Geeignet zu alle Typen von Traktoren.

 Machine à désherber hydraulique entre rangées avec double tête de broyage. Conçue pour couper l'herbe sous les arbres dans des vergers et des vignobles. Disponible système hydraulique autonome et structure indépendante.

 Desbrozadora de interfilas hidráulica con un doble cabezal para la limpieza mecánica entre las líneas de la plantas en viñedos y frutales. Este modelo está provisto de un bastidor portante y de un sistema hidráulico independiente.

Mod.	 HP								
	Min	Max	cm	n°	mm	α°	cm	min	max
<b>ECOSPRINT/D 180-280</b>	50	100	75 x 2	16 + 16	900   900 1400   1400	-5° → + 45°	10	670	710
<b>ECOSPRINT/D 230-350</b>	50	100	75 x 2	16 + 16	1150   1150 1750   1750	-5° → + 65°	15	710	750

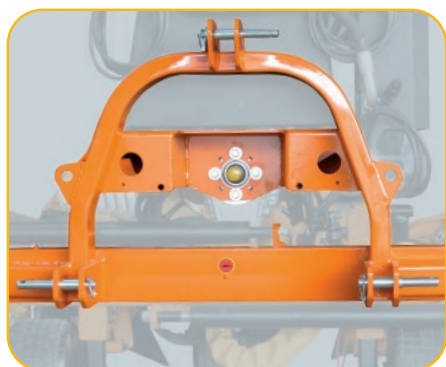

- Telaio con attacco ai tre punti I-II<sup>A</sup> Cat.
- Independent Frame with 3-point linkage Cat I-II.
- Eigene Tragrahmen mit Dreipunkbock Kat. I-II.
- Structure indépendante avec attelage 3 points cat. I et II.
- Conexión independiente al 3º punto del tractor, Cat I y II.

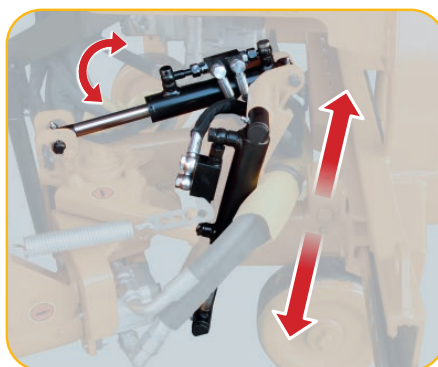

- Martinetti idraulici per la regolazione dell'altezza e dell'inclinazione di lavoro completi di tubi ed innesti rapidi.
- Hydr. cylinders for height and tilt adjustment of mower head with hydraulic hoses and quick couplers.
- Hydr. Zylindern für Höhenverstellung und Neigungsverstellung des Mähkopf mit Schlauchen und Schnellkupplungen.
- Vérins hydrauliques pour réglage de l'hauteur et de l'inclinaison de la tête, avec flexibles et prises rapides.
- Cilindros hidráulicos para ajuste de altura e inclinación del cabezal con mangueras hidráulicas y acopladores rápidos.

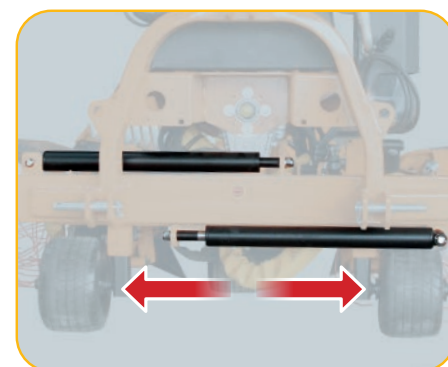

- Martinetti idraulici per lo spostamento laterale completo di tubi ed innesti rapidi.
- Hydr. cylinders for side shift with hydraulic hoses and quick couplers.
- Hydr. Zylindern für Seitenverschiebung mit Schlauchen und Schnellkupplungen.
- Vérins hydrauliques pour déport avec flexibles et prises rapides.
- Cilindros hidráulicos de desplazamiento lateral con mangueras hidráulicas y acopladores rápidos.





- Tensionamento meccanico della testata.
- Mechanical tensioning of the head.
- Mechanische Spannung des Kopfes.
- Tension mécanique de la tête.
- Tensor mecánico de la cabeza.

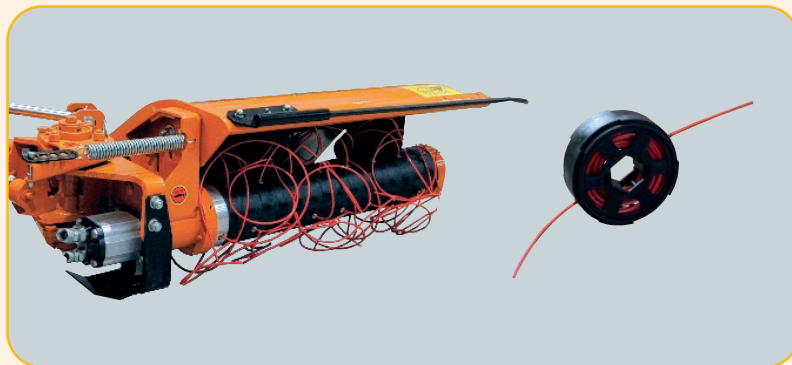

- Testata completa di bobine (brevettato).
- Mower head with for wire-spools (patented).
- Mähkopf mit Drahtspulen (patentiert).
- Tête de broyage avec bobines de fil (breveté).
- Cabezal desbrozador con carretes de filamentos de Nylon (patentado).



- Centralina oleodinamica autonoma.
- Independent hydraulic system.
- Hydraulische Selbstversorgungsanlage.
- Centrale hydraulique indépendante.
- Sistema hidráulico independiente.



- Scambiatore di calore.
- Oil Cooler.
- Ölkühler.
- Refroidisseur d'huile.
- Refrigerador de aceite.



- Comando elettrico Joystick con distributore ed elettrovalvole.
- Electric Controls for all functions.
- Elektrische Steuerung mit Joystick Bedienung (alle Funktionen).
- Commande électrique avec joystick pour toutes les fonctions.
- Control electronico de funciones con Joystick.

## OPTIONALS



- Ruote (n°3) in gomma regolabili in altezza.
- Supporting rubber wheels (n°3), height adjustable.
- Höhenverstellbare Stützräder (N°3) aus Gummi.
- Roues de caoutchouc (n°3), réglables en hauteur.
- Ruedas de goma (n°3) regulables en altura.



- Avvolgifiло meccanico.
- Mechanical winder for wire-spool.
- Wickelapparat für Drahtspule.
- Bobineuse mécanique pour fil.
- Enrollador mecánico de los filamentos.



- Albero cardanico.
- Pto drive shaft.
- Gelenkwelle.
- Arbre cardan.
- Eje cardan.

# ECOROW



**HARDOX®**  
WEAR PLATE



Diserbatrice **singola** a regolazione idraulica predisposto per l'applicazione di dischi a stella e a dito per la lavorazione del terreno sottofila tra le piante, applicabile in posizione frontale o posteriore al trattore oppure su trattori con guida retroversa.



Front and rear between-row mower (**single**), hydraulically adjustable, designed for the application of star discs and finger discs, for weed control and soil cultivating along the plants' row.



Front und Heck Maher-Gerät (**Einzel**), mit hydraulischer Regulierung für die Anwendung von Stern- und Fingerscheiben zur Bearbeitung des Bodens unterhalb und zwischen Pflanzenreihen



Machine réversible (**simple**) à réglage hydraulique, compatible avec les têtes en forme d'étoile et les bineuses à doigts pour le désherbage mécanique et labourer la terre entre les plantes et sous-rang.



Desmalezadora reversible (**individual**) de regulación hidráulica predispuesta para la aplicación de discos de estrella y con dedo, para el deshierbe mecánico y para el cultivo de la tierra bajo fila entre las plantas.

Mod.	HP		n°	SERIE V	SERIE F	SERIE V	SERIE F
	Min	Max		mm	mm	min-max	min-max
<b>ECOROW</b>	50	100	2	800 1325	1125 1975	300-390	390-480
<b>ECOROW</b>	50	100	3	875 1400	1200 2050	310-400	400-490
<b>ECOROW</b>	50	100	4	800 1325	1125 1975	320-410	410-500
<b>ECOROW</b>	50	100	5	875 1400	1200 2050	330-440	420-510



- Attacco ai tre punti reversibile, Cat. I-II.
- Reversible 3-points linkage, Cat. I-II.
- Umkehrbarer Dreipunktbock, Kat. I-II.
- Attelage réversible à 3 points, I-II.
- Enganche a los 3 puntos reversible, Cat. I-II.



- Martinetto idraulico indipendente per allargamento telaio.
- Hydr. independent cylinder for frame adjustment.
- Hydr. Zylinder für Öffnung des Rahmen.
- Vérin hydraulique indépendant pour réglage de la structure.
- Gato hidráulico independiente para ensanchamiento del chasis.



- Telaio reversibile per uso anteriore e posteriore.
- Front and rear mount, by swapping the sides.
- Front/Heck- Anbau, durch Vertauschen der Seiten.
- Montage avant et arrière, en inversant les côtés.
- Montaje delantero y trasero, intercambiando los lados.

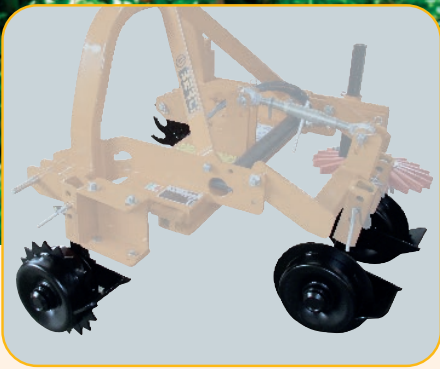

- Ruote d'appoggio in ferro, regolabili in altezza e ruota d'appoggio laterale.
- Metal support wheels, height adjustable and side support wheel.
- Höhenverstellbare Stützräder aus Eisen und Seitliches Stützrad.
- Roues d'appui en fer, réglables en hauteur et roue d'appui latéral.
- Ruedas de apoyo en hierro, regulables en altura y rueda de apoyo lateral.

- Disco a stella (2-3-4-5 pezzi).
- Star disc (2-3-4-5 pieces).
- Sternscheibe (2-3-4-5 Stück).
- Tête en forme d'étoile (2-3-4-5 pièces).
- Disco de estrella (2-3-4-5 piezas).

## OPTIONALS

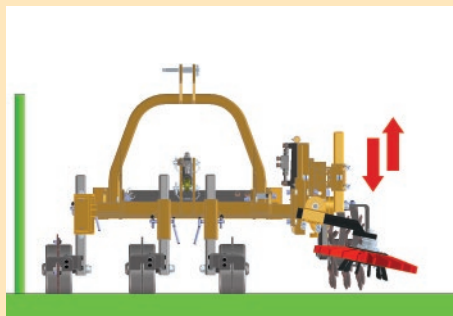

- Alzata idraulica del corpo laterale con tubi ed innesti rapidi.
- Hydraulic lift of the side with hoses and quick couplings.
- Hydraulischer Höhenverstellung der Seite mit Schläuchen und Schnellkupplungen.
- Levée hydraulique de côté avec tuyaux et prises rapides.
- Elevación hidráulica del lado con tubos y acoples rápidos.



SOFT

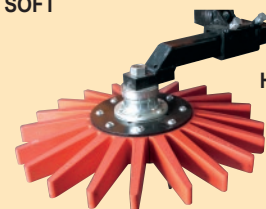

HARD

- Disco a dito (Ø 54 - Ø 70).
- Finger disc (Ø 54 - Ø 70).
- Fingerscheibe (Ø 54 - Ø 70).
- Bineuse à doigts (Ø 54 - Ø 70).
- Disco de dedo (Ø 54 - Ø 70).



- Kit denti per ruote.
- Teeth kit for wheels.
- Satz Zähne für Räder.
- Jeu dents pour roues.
- Kit dientes para ruedas.

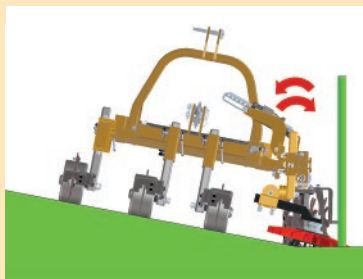

- Inclinazione idraulica del corpo laterale con tubi e innesti rapidi.
- Hydraulic tilt of the side with hoses and quick couplings.
- Hydraulischer Neigungsverstellung der Seite mit Schläuchen und Schnellkupplungen.
- Inclinaison hydraulique de côté avec tuyaux et prises rapides.
- Inclinación hidráulica del lado con tubos y acoples rápidos.



- Parasassi.
- Stones guard kit.
- Satz Steinschutzblechen.
- Jeu para-cailloux.
- Kit protección da piedras.



- Kit joystick 3 funzioni con elettrovalvole.
- Electro-hydraulic controls, three functions, with joystick.
- Elektrohydraulische Bedienung, drei Funktionen, mit Joystick.
- Commandes électriques, trois fonctions, avec Joystick.
- Kit joystick tres funciones con electroválvulas.



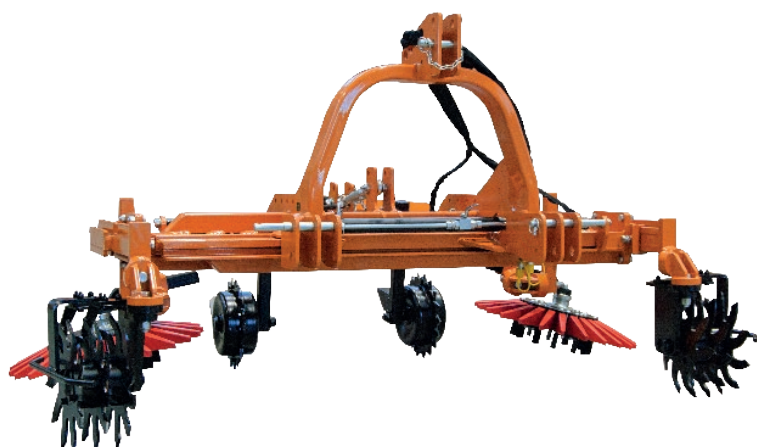

- Ruote in gomma posteriori (2X).
- Rear rubber wheels (2X).
- Laufrollen aus Gummi (2X).
- Roues arrière en caoutchouc (2X).
- Ruedas en goma posteriores (2X).

# ECOROW/D





**HARDOX®**  
WEAR PLATE







 Diserbatrice **doppia** a regolazione idraulica predisposto per l'applicazione di dischi a stella e a dito per la lavorazione del terreno sottofila tra le piante, applicabile in posizione frontale o posteriore al trattore oppure su trattori con guida retroversa.

 Front and rear between-row mower (**double**), hydraulically adjustable, designed for the application of star discs and finger discs, for weed control and soil cultivating along the plants' row.

 Front und Heck Maher-Gerät (**Doppel**), mit hydraulischer Regulierung für die Anwendung von Stern- und Fingerscheiben zur Bearbeitung des Bodens unterhalb und zwischen Pflanzenreihen

 Machine réversible (**Double**) à réglage hydraulique, compatible avec les têtes en forme d'étoile et les bineuses à doigts pour le désherbage mécanique et labourer la terre entre les plantes et sous-rang.

 Desmalezadora reversible (**Doble**) de regulación hidráulica pre-dispuesta para la aplicación de discos de estrella y con dedo, para el deshierbe mecánico y para el cultivo de la tierra bajo fila entre las plantas.

Mod.	 HP		 n°	SERIE <b>V</b>	SERIE <b>F</b>	SERIE <b>V</b>	SERIE <b>F</b>
	Min	Max		 mm	 mm	 min-max	 min-max
<b>ECOROW/D</b>	50	100	2-2	800   800 1325   1325	1125   1125 1975   1975	440-615	620-795
<b>ECOROW/D</b>	50	100	3-3	875   875 1400   1400	1200   1200 2050   2050	460-635	640-815
<b>ECOROW/D</b>	50	100	4-4	800   800 1325   1325	1125   1125 1975   1975	480-655	660-835
<b>ECOROW/D</b>	50	100	5-5	875   875 1400   1400	1200   1200 2050   2050	500-675	680-855

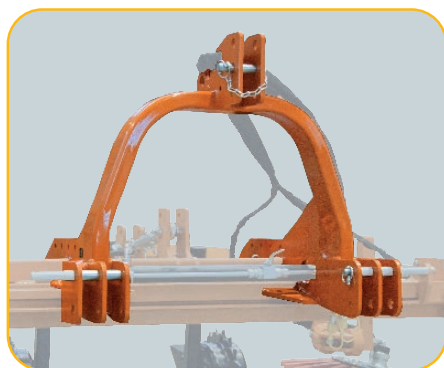

- Attacco ai tre punti reversibile, Cat. I-II.
- Reversible 3-points linkage, Cat. I-II.
- Umkehrbarer Dreipunktbock, Kat. I-II.
- Attelage réversible à 3 points, I-II.
- Enganche a los 3 puntos reversible, Cat. I-II.

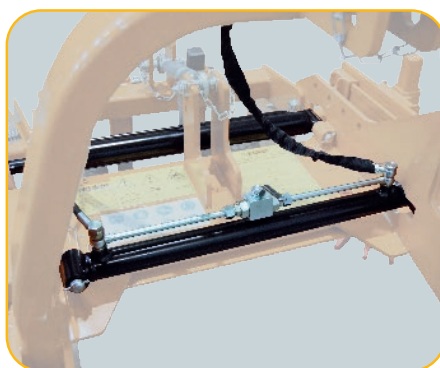

- Martinetti idraulici sincronizzati per allargamento telaio.
- Hydr. synchronized cylinders for frame adjustment.
- Hydr. synchronisierte Zylindern für Öffnung des Rahmen.
- Vérins hydrauliques synchronisés pour réglage de la structure.
- Gatos hidráulicos sincronizados para ensanchamiento del chasis.



- Telaio reversibile per uso anteriore e posteriore.
- Front and rear mount, by swapping the sides.
- Front/Heck- Anbau, durch Vertauschen der Seiten.
- Montage avant et arrière, en inversant les côtés.
- Montaje delantero y trasero, intercambiando los lados.

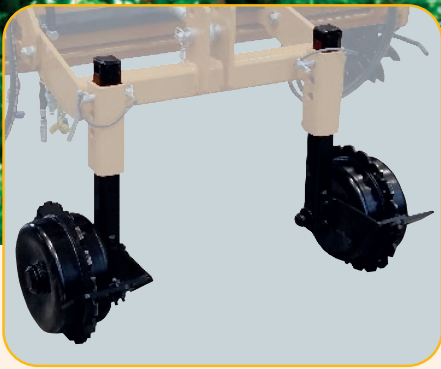

- Ruote d'appoggio in ferro, regolabili in altezza.
- Metal support wheels, height adjustable.
- Höhenverstellbare Stützräder aus Eisen.
- Roues d'appui en fer, réglables en hauteur.
- Ruedas de apoyo en hierro, regulables en altura.



- Disco a stella (2-3-4-5 pezzi).
- Star disc (2-3-4-5 pieces).
- Sternscheibe (2-3-4-5 Stück).
- Tête en forme d'étoile (2-3-4-5 pièces).
- Disco de estrella (2-3-4-5 piezas).



SOFT

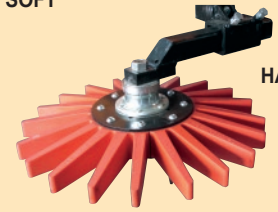

HARD

- Disco a dito (Ø 54 - Ø 70 - Ø 100).
- Finger disc (Ø 54 - Ø 70 - Ø 100).
- Fingerscheibe (Ø 54 - Ø 70 - Ø 100).
- Bineuse à doigts (Ø 54 - Ø 70 - Ø 100).
- Disco de dedo (Ø 54 - Ø 70 - Ø 100).

## OPTIONALS

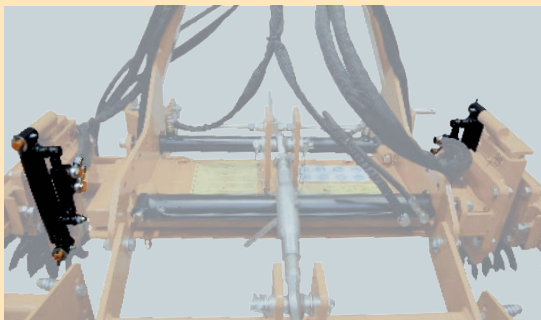

- Alzate idrauliche dei corpi laterali con tubi ed innesti rapidi.
- Hydraulic lift of the sides with hoses and quick couplings.
- Hydraulischer Höhenverstellung der Seiten mit Schläuchen und Schnellkupplungen.
- Levée hydraulique des côtés avec tuyaux et prises rapides.
- Elevación hidráulica de los lados con tubos y acoples rápidos.

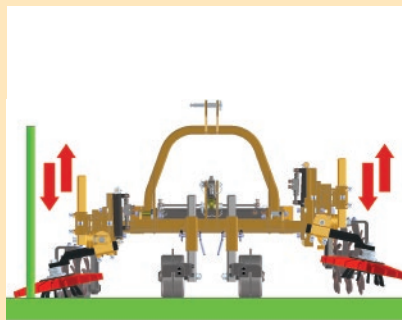

- Inclinazioni idrauliche dei corpi laterali con tubi e innesti rapidi.
- Hydraulic tilt of the sides with hoses and quick couplings.
- Hydraulischer Neigungsverstellung der Seiten mit Schläuchen und Schnellkupplungen.
- Inclinaison hydraulique des côtés avec tuyaux et prises rapides.
- Inclinação hidráulica de los lados con tubos y acoples rápidos.



- Kit denti per ruote.
- Teeth kit for wheels.
- Satz Zähne für Räder.
- Jeu dents pour roues.
- Kit dientes para ruedas.

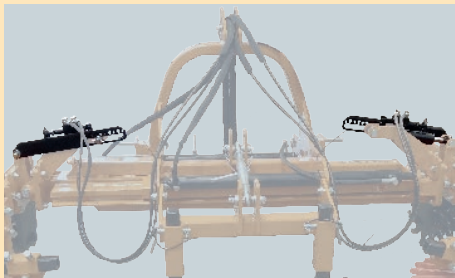

- Kit parasassi.
- Stones guard kit.
- Satz Steinschutzblechen.
- Jeu para-cailloux.
- Kit protección da piedras.

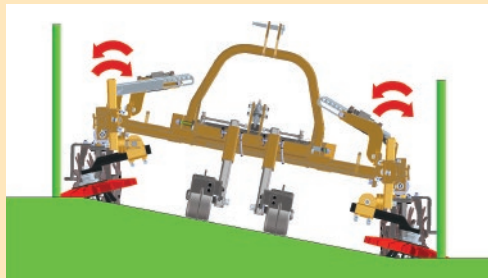

- Kit joystick 3/5 funzioni con elettrovalvole.
- Electro-hydraulic controls, three/five functions, with joystick.
- Elektrohydraulische Bedienung, drei/fünf Funktionen, mit Joystick.
- Commandes électriques, trois/cinq fonctions, avec Joystick.
- Kit joystick tres/cinco funciones con electroválvulas.



- Ruote in gomma posteriori (2X).
- Rear rubber wheels (2X).
- Laufräder aus Gummi (2X).
- Roues arrière en caoutchouc (2X).
- Ruedas en goma posteriores (2X).

# DATI TECNICI

## DATA TABLES / TECHNISCHE DATEN / FICHES TECHNIQUES / DATOS TÉCNICOS

### ECOSPRINT / EASY

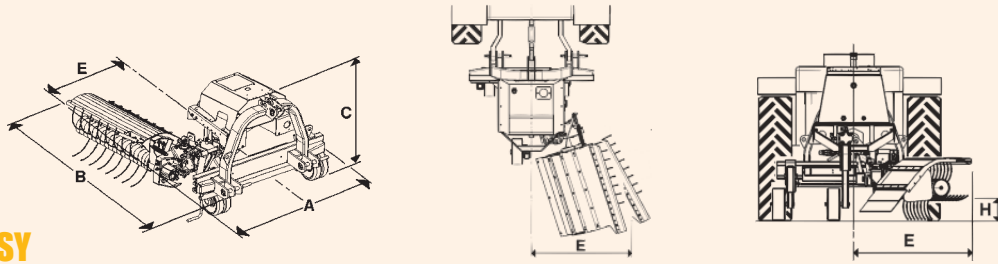

	A		B	C	E		H	
	Min cm	Max cm			Min cm	Max cm	Min cm	Max cm
<b>ECOSPRINT/EASY 90-140</b>	150	200	175	103	90	140	15	25
<b>ECOSPRINT/EASY 140-240</b>	220	320	175	103	140	240	15	30

### ECOSPRINT

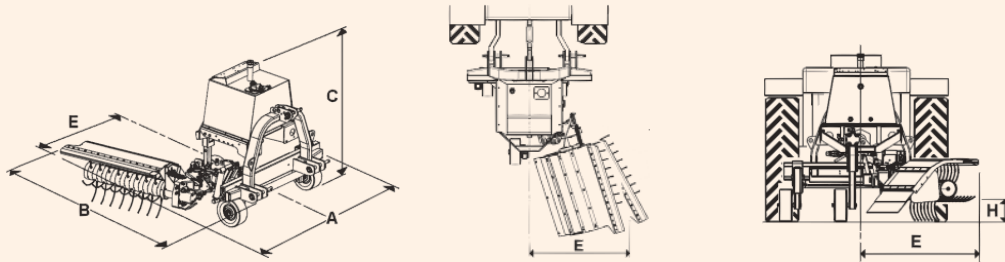



	A		B	C	E		H	
	Min cm	Max cm			Min cm	Max cm	Min cm	Max cm
<b>ECOSPRINT 90-140</b>	150	200	175	125	90	140	15	25
<b>ECOSPRINT 140-240</b>	220	320	175	125	140	240	15	30

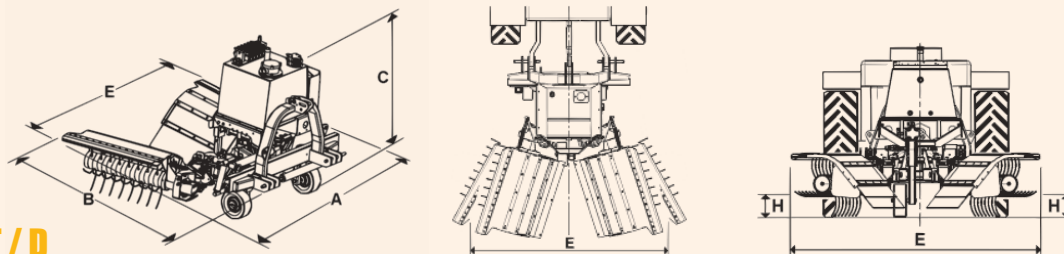

### ECOSPRINT / D







	A		B	C	E		H	
	Min cm	Max cm			Min cm	Max cm	Min cm	Max cm
<b>ECOSPRINT/D 180-280</b>	150	280	175	130	180	280	15	25
<b>ECOSPRINT/D 230-350</b>	200	350	175	130	230	350	15	30

Le illustrazioni e i dati del presente catalogo sono indicative e non vincolanti per il costruttore • All pictures and data above are indicative only and not binding for the manufacturer • Alle in diesem Katalog enthaltenen Angaben und Zeichnungen sind annahmend und unverbindlich • Toutes les données insérées dans ce catalogue ont été indiquées seulement à titre de renseignement • Las fotografías y los datos mostrados son meramente indicativos y podrán ser variados sin previo aviso por el fabricante.

Serie V		A*		B	C	D	
		Min cm	Max cm				
<b>ECOROW</b>	2	153	205	135	130	73	15
<b>ECOROW</b>	3	160	213	135	130	73	22
<b>ECOROW</b>	4	160	213	135	130	73	29
<b>ECOROW</b>	5	160	213	135	130	73	36

Serie F		A*		B	C	D	
		Min cm	Max cm				
<b>ECOROW</b>	2	220	305	135	130	107	15
<b>ECOROW</b>	3	227	312	135	130	107	22
<b>ECOROW</b>	4	220	305	135	130	107	29
<b>ECOROW</b>	5	227	312	135	130	107	36

Serie V		A*		B	C	
		Min cm	Max cm			
<b>ECOROW/D</b>	2+2	160	265	135	130	15+15
<b>ECOROW/D</b>	3+3	175	280	135	130	22+22
<b>ECOROW/D</b>	4+4	160	265	135	130	29+29
<b>ECOROW/D</b>	5+5	175	280	135	130	36+36

Serie F		A*		B	C	
		Min cm	Max cm			
<b>ECOROW/D</b>	2+2	225	395	135	130	15+15
<b>ECOROW/D</b>	3+3	240	410	135	130	22+22
<b>ECOROW/D</b>	4+4	225	395	135	130	29+29
<b>ECOROW/D</b>	5+5	240	410	135	130	36+36

## ECOROW

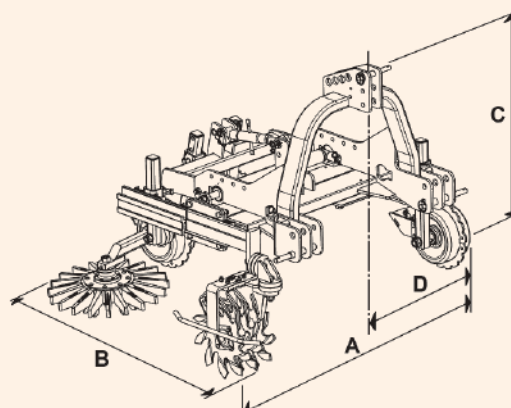

## ECOROW / D

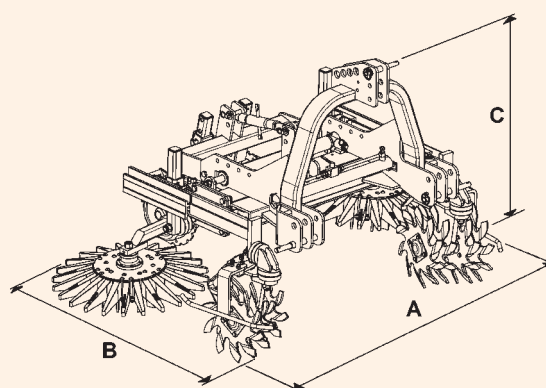

Le illustrazioni e i dati del presente catalogo sono indicative e non vincolanti per il costruttore • All pictures and data above are indicative only and not binding for the manufacturer • Alle in diesem Katalog enthaltenen Angaben und Zeichnungen sind annahmend und unverbindlich • Toutes les données insérées dans ce catalogue ont été indiquées seulement à titre de renseignement • Las fotografías y los datos mostrados son meramente indicativos y podrían ser variados sin previo aviso por el fabricante.



www.bertima.it



ECOSPRINT<sup>®</sup>/easy



ECOSPRINT<sup>®</sup>



ECOSPRINT<sup>®</sup>/D



ECOROW

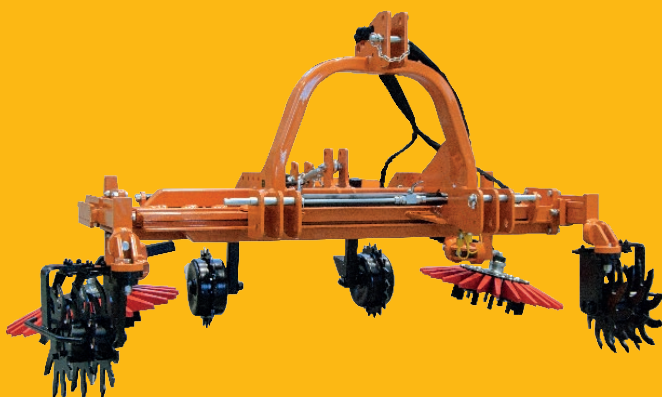

ECOROW/D

Le illustrazioni e i dati del presente catalogo sono indicative e non vincolanti per il costruttore. • All pictures and data above are indicative only and not binding for the manufacturer. • Alle in diesem Katalog enthaltenen Angaben und Zeichnungen sind annähernd und unverbindlich. • Toutes les données insérées dans ce catalogue ont été indiquées seulement à titre de renseignement. • Las fotografías y los datos mostrados son meramente indicativos y podrían ser variados sin previo aviso por el fabricante.



**BERTI**<sup>®</sup>  
MACCHINE AGRICOLE



Via Musi, 1/A-3-4 - 37042 Caldiero (VR) ITALY  
Tel. +39.045.6139711 - Fax +39.045.6150251  
info@bertima.it



MADE IN ITALY

D010.19 - REV2